

TTL Counter and Digital I/O Board

ME-1400 - up to 30 Counters, up to 48 Digital I/O Channels

Model:
ME-1400

Platform:

- PCI
- PXI/cPCI
- USB
- Other

Functions:

- Analog I/O
- Digital I/O
- Temp./°C
- Interfaces
- Instrument
- Logger
- Isolation
- Accessory
- Software

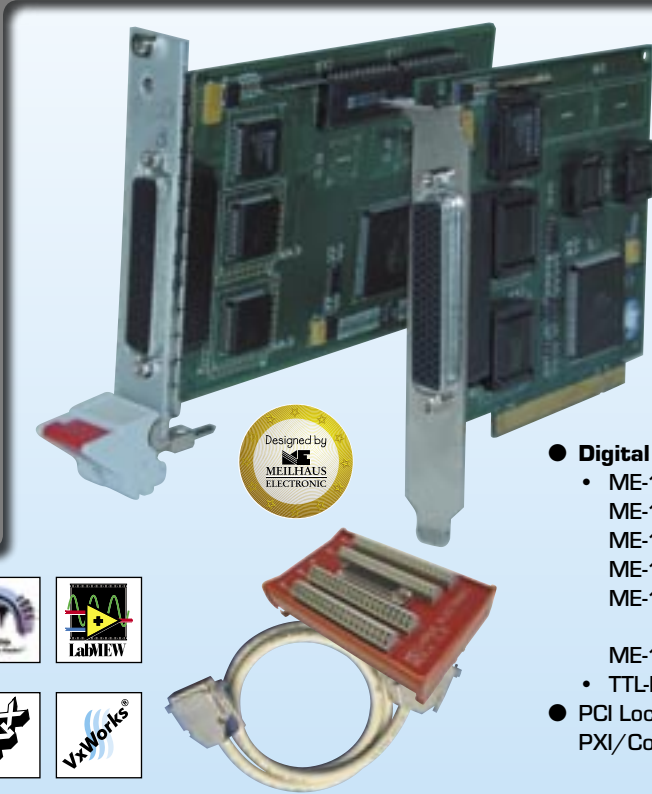

● **Counters:**

- ME-1400A: 3x 16 bit counters.
 - ME-1400B: 6x 16 bit counters.
 - ME-1400C: 15x 16 bit counters.
 - ME-1400D: 15x 16 bit counters (expansion for ME-1400C).
- ME-1400C and expansion D connected together for **30 counter!**
- TTL level.
 - Independent, programmable counters.
 - Counters **can be cascaded via software.**
 - 1 or 10 MHz clock (quartz oscillator) independent from PC clock.
 - Models with counters: Interrupt control.

● **Digital I/O channels:**

- ME-1400: 24 channels digital I/O.
 - ME-1400A: 24 channels digital I/O.
 - ME-1400B: 48 channels digital I/O.
 - ME-1400C: 24 channels digital I/O.
 - ME-1400D: 24 channels digital I/O (expansion for ME-1400C).
- ME-1400C and D together for **48 channels.**
- TTL-Pegel.
- PCI Local Bus 2.1 compatible. Plug'n'Play. StandardPCI or 3 U PXI/CompactPCI versions (except ME-1400C/D: PCI only).

Software:

ME-Power-CD included:

- Drivers for **Windows** XP, 2000, 98/Me, NT. Visual C++, Delphi, Visual Basic and Borland C/C Builder supported.
- Drivers for **Agilent VEE, LabVIEW.**
- Drivers for **Linux** (source code under GPL).
- Treiber¹⁾ for **VxWorks** 5.4.2.
- Treiber¹⁾ for **GNX** (source code under GNX Community License).
- Utilities, examples, demos.
- "Soft manuals" in English and German for Acrobat Reader/PDF.

1) nur ME-1400, ME-1400A, ME-1400B

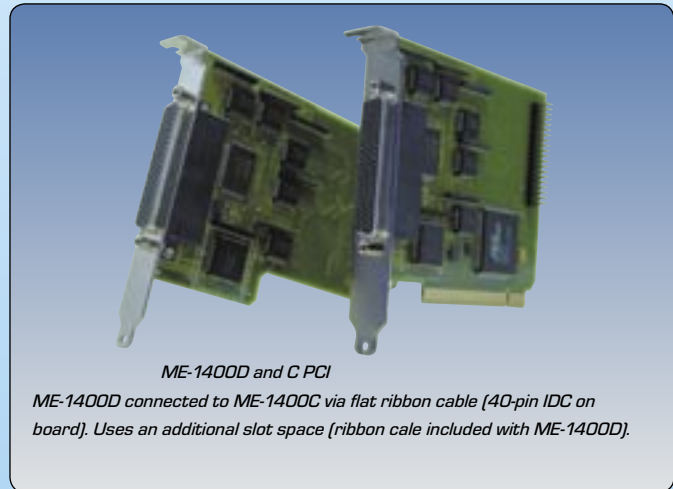

ME-1400D and C PCI
ME-1400D connected to ME-1400C via flat ribbon cable (40-pin IDC on board). Uses an additional slot space (ribbon cable included with ME-1400D).

Ordering Codes:

- ME-1400 PCI**
PCI 24 channels TTL digital I/O board
- ME-1400A PCI**
PCI 24 chan. TTL digital I/O board, 3 counters
- ME-1400B PCI**
PCI 48 chan. TTL digital I/O board, 6 count.
- ME-1400C PCI**
PCI 15 counter and 24 channel TTL digital I/O board. Incl. cable ME AK-D78/1400CD.
- ME-1400D EXP with PCI slot bracket**
PCI 15 counter and 24 channel TTL digital I/O board. Expansion board for ME-1400C. Incl. cable ME AK-D78/1400CD
- ME-1400E PCI**
- ME-1400EA PCI**
- ME-1400EB PCI**
see above, but 37-pin (instead of 78-pin) D-sub female, compatible with ME-14

- ME-1400 cPCI**
 - ME-1400A cPCI**
 - ME-1400B cPCI**
see above, but PXI/CompactPCI versions
- Accessories:**
- Cable ME AK-D78/1** **1 m**
 - Cable ME AK-D78** **2 m**
78-pin D-sub male-female (1:1 wired). Connects ME-1400 and terminal block, user application or ME-Xtend series
 - Terminal block ME AB-D78M**
78-pin D-sub male and spring terminals
 - Cable ME AK-D37** **2 m**
 - Terminal block ME AB-D37M**
37-pin cable (male-female, 1:1 wired) and terminal block with spring terminals for series -E

- Cable ME AK-D78/1400CD** **1 m**
78-pin D-sub male and open ends; shielded special cable for ME-1400C and D (1x included)
- ME-63Xtend and ME-UB series**
External expansion boards/boxes with relays or opto-isolation.
- Cable ME AK-D7815/1400**
25-pin D-sub male and 3x 15-pin D-sub male. Connects ME-1400 and 3x ME-UB series
- Cable ME AK-D25** **2 m**
25-pin D-sub male and 25-pin D-sub female (1:1 wired). Connects ME-63Xtend series (remaining ME-1400(A) signals) with terminal block
- Terminal block ME AB-D25M**
25-pin D-sub male and spring terminals

Web Link: www.meilhaus.com/e_me

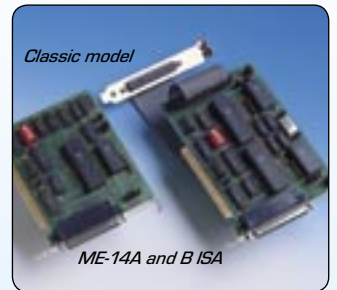
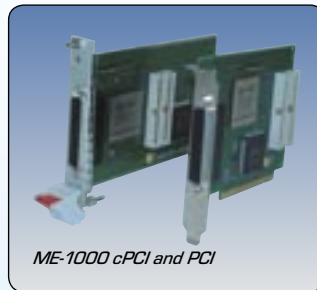
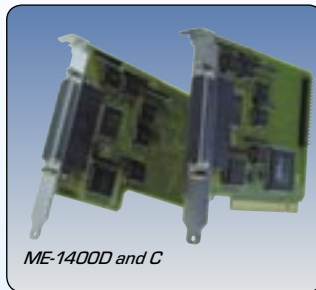
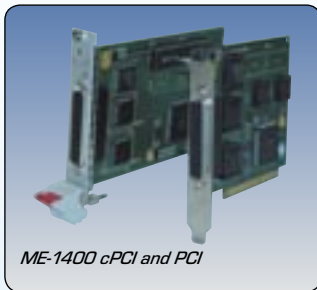

Model Overview:		ME-1400, ME-14, ME-1000			
TTL I/O Channels	16 bit Count.	Interrupt	D-Sub Female	Model	Bus
24 ²⁾³⁾	-	-	78-pin	ME-1400 PCI	PCI
24 ²⁾	3	√	78-pin	ME-1400A PCI	PCI
48	6	√	78-pin	ME-1400B PCI	PCI
24	15	√	78-pin	ME-1400C PCI	PCI
24	15	√	78-pin	ME-1400D EXP PCI	PCI ⁴⁾
24 ²⁾³⁾	-	-	78-pin	ME-1400 cPCI	PXI/ CompactPCI
24 ²⁾	3	√	78-pin	ME-1400A cPCI	PXI/ CompactPCI
48	6	√	78-pin	ME-1400B cPCI	PXI/ CompactPCI
24	-	-	37-pin ⁵⁾	ME-1400E PCI	PCI
24	3	√	37-pin ⁵⁾	ME-1400EA PCI	PCI
48	6	√	37-pin ⁵⁾	ME-1400EB PCI	PCI
64 ²⁾	-	-	78-pin	ME-1000/64 PCI	PCI
128 ²⁾	-	-	78-pin	ME-1000/128 PCI	PCI
64 ²⁾	-	-	78-pin	ME-1000/64 cPCI	PXI/ CompactPCI
128 ²⁾	-	-	78-pin	ME-1000/128 cPCI	PXI/ CompactPCI
24	3	√	37-pin	ME14A ISA	ISA ⁶⁾
48	6	√	37-pin	ME-14B ISA	ISA ⁶⁾

- 2) Can be used to control ME-63Xtend series boards.
- 3) Can be used to control ME-UB series boxes.
- 4) Expands ME-1400C PCI, uses slot space, but doesn't require slot connector.
- 5) Pinning compatible with ME-14 ISA.
- 6) "Classic" ISA models available while supplies last. After that, boards can be ordered in larger quantities only for support of running applications.

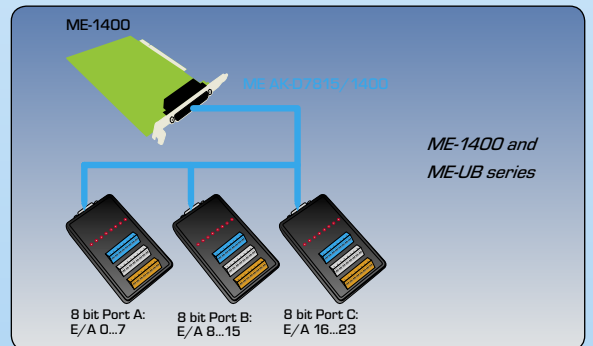
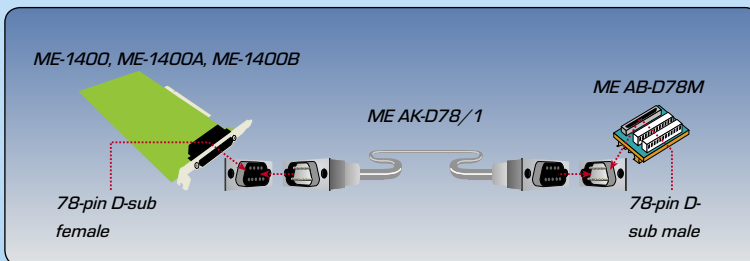
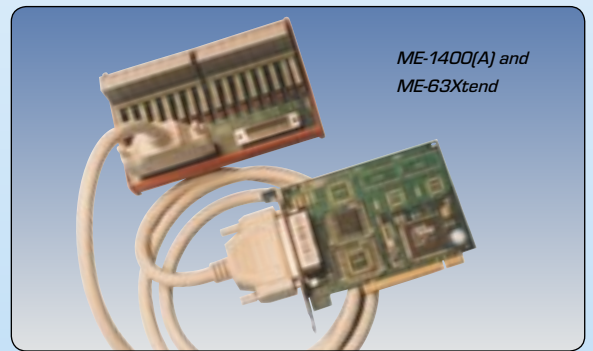
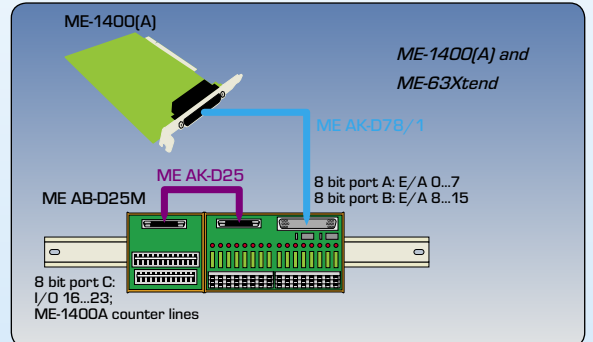

Specifications:					
Digital I/O (TTL)	ME-1400	ME-1400A	ME-1400B	ME-1400C	ME-1400D
Number	24	24	48	24	24
Type	TTL compatible				
Voltage,	input: Low: -0.5...+0.8 V ($I_{Lmax} = \pm 10 \mu A$); high: +2.0...5.5 V ($I_{Hmax} = \pm 10 \mu A$) output: Low: Max. 0.45 V ($I_{OL} = 1.7 \text{ mA}$); high: Min. 2.4 V ($I_{OH} = -200 \mu A$)				
Counters	ME-1400	ME-1400A	ME-1400B	ME-1400C	ME-1400D
Number	-	3	6	15	15
Type	Independent 16 bit counters, can be cascaded via software. Compatible with 8254. TTL level. All lines wired to D-sub				
Voltage,	input Low: -0.5...+0.8 V ($I_{Lmax} = \pm 10 \mu A$); high: +2.2...6 V ($I_{Hmax} = \pm 10 \mu A$) output Low: Max. 0.45 V ($I_{OL} = 2.2 \text{ A}$); high: Min. 2.4 V ($I_{OH} = -400 \mu A$)				
Quartz oscillator	1 MHz/ 10 MHz software selectable; accuracy: $\pm 100 \text{ ppm}$ ($\pm 0.01\%$). Clock available at D-sub. The clock output line (clock out) can also be used as interrupt input (IRQ in, software selectable)				
General Data					
Bus interface	Depending on model 32 bit/33 MHz StandardPCI bus or PXI/ CompactPCI bus. PCI Local Bus 2.1 compatible				
Size (mm)	PCI: ~ 174 x 98; PXI/ CompactPCI: 160 x 100 (3 U Europa card format)				
Connectors	78-pin D-sub female. Models E: 37-pin D-sub female, pinning compatible with ME-14 ISA + version B second 37-pin D-sub female with slot bracket Model C: 40-pin flat ribbon connector; connects ME-1400D to ME-1400C				

Inside ME Series: ME-1400 Family

Puls Width Modulation (PWM)

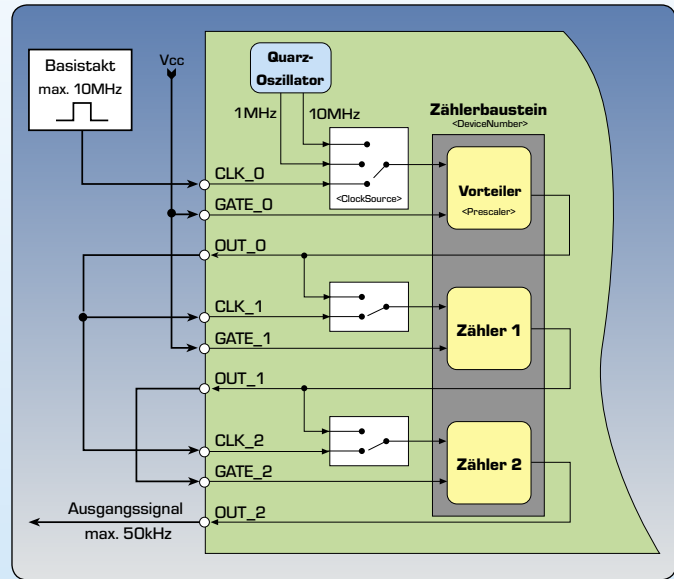
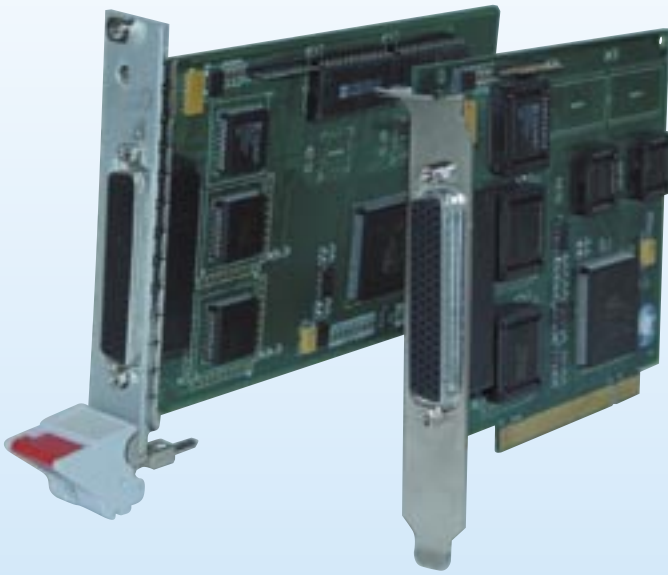

ME-1400 Counters

The TTL counter and digital I/O board series ME-1400 is available in the following versions. Only the models with counters (marked yellow) can be used for the puls width modulation described in this application note:

Model	Bus	Digital I/O	16 bit Counters	PWM
ME-1400 PCI	PCI	24	-	-
ME-1400A PCI	PCI	24	3	✓
ME-1400B PCI	PCI	48	6	✓
ME-1400C PCI	PCI	24	15	✓
ME-1400D PCI	(PCI) ¹⁾	24	15	✓
ME-1400 cPCI	PXI/CompactPCI	24	-	-
ME-1400A cPCI	PXI/CompactPCI	24	3	✓
ME-1400B cPCI	PXI/CompactPCI	48	6	✓

1) Externe Erweiterungs-Karte zur ME-1400C, belegt einen weiteren Einbauplatz, benötigt jedoch keinen eigenen PCI-Slot

The timer chip on the ME-1400 boards is compatible with the widely known 8254. One of these timer chips has three 16 bit counters, i. e. the ME-1400A has one timer chip with three 16 bit counters, the ME-1400B has 2 timer chips with three 16 bit counters each (= 6 counters) and the ME-1400C or D have 5 timer chips with three 16 bit counters each (= 15 counters).

Puls Width Modulation

With a special external circuitry (see below) the three counters of each timer chip can be used to output a pulse signal with variable duty cycle. The duty cycle can vary between 1...99% in steps of 1%.

The base clock can be taken from an external frequency generator (max. 10 MHz) or from the internal quartz oscillator (1 MHz or 10 MHz). You can vary the frequency in the range of (base clock)/2 and (base clock)/65535 using the prescaler.

There is a parameter to set the duty cycle in the range of 1...99% in steps of 1%. The signal output is always available at counter 2 OUT of the timer chip in use (OUT_2, OUT_5 etc.). The signal frequency can be up to max. 50 kHz. The software driver

An external base clock (max. 10 MHz) can be connected. Or you can use the internal quartz oscillator clock of 1 MHz or 10 MHz. The source of the base clock is software selectable.

Counter 0 can be used as prescaler for the signal. The signal frequency can be up to max. 50 kHz. The duty cycle can be set in the range of 1...99% in steps of 1%. Output is started immediately by calling the function ...CntPWMStart. Output can be stopped by calling the function ...CntPWMStop gestoppt. No further programming of the counters is required.

The modulation of the signals is carried out by corresponding changes of the duty cycle.

included with the ME-1400 has two functions which simplify the output of square signals with a selectable duty cycle. The picture below shows the external circuitry, which has to be added to the board for this application:

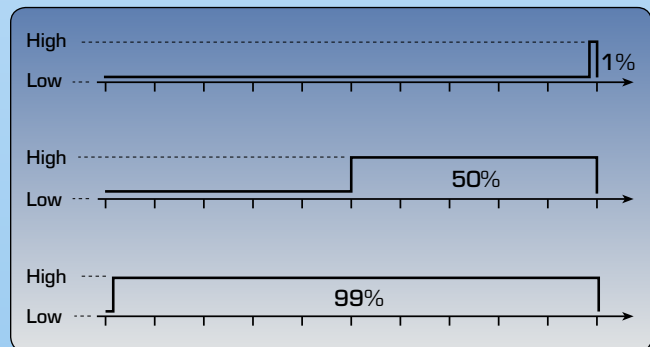

me1400CntPWMStart

This function configures the 3 counters of a timer chip for the operating mode puls width modulation (PWM). It starts the output of a square signal with the selected duty cycle at the output of counter 2 of the timer chip in use (eg. OUT_2).

me1400CntPWMStop

This function stops the signal output.