



## R3000 FRONT END AC-DC POWER SHELF

AC Input: 180V to 264V  
DC Output: 48V to 57V, 3000W

### Product Specification

#### FEATURES

- ❑ **Rack mount chassis (19", 1U high)**
- ❑ **1U, 2U, 3U & 4U stackable for higher wattage power - 12,000W**
- ❑ **Parallel operation which can house up to 3 x A1000 series power modules**
- ❑ **Up to 2000W of N+1 Redundant operation.**
- ❑ **Configurable local and remote sense of output bus voltage**
- ❑ **Power Fail Warning & Fault Alarm**
- ❑ **Compatible with worldwide power sources. (Universal AC Input )**
- ❑ **I<sup>2</sup>C Optional**
- ❑ **Local and Remote Monitoring Control**
- ❑ **Hot Swap**

The Powerstax R3000 series of front-end power shelves is designed to operate as a key element in a complete distributed power system. It is a very low profile 1U high 43.4mm (1.71") sub-assembly that mounts into a 19" rack.

The power shelf mates to a commercial power grid and when assembled with power modules, generates a precisely regulated DC bus voltage.

This power shelf can house up to three Powerstax A1000 power modules and provides protection, and a number of alarm and control features. This product is intended for integration into end-use equipment.

The power shelf can supply up to 2000W of N+1 redundant power or up to 3000W of total power depending on configuration of power modules. Four stacked shelves can provide up to 12,000W total power.





### Input Connector

The R3000 series power shelves can be used with any standard global line voltages. The standard AC input connection to the shelf is through three IEC320 type connector rated at 10A / 250Vac in Europe/Asia and 15A /120Vac in North America.

### Output Connector

The shelf has two terminal blocks for DC output (each with three M4 screws). They are labelled V+ and V-, respectively, on the body of the terminal block. The V+ and V- are floating with respect to frame GND. Frame GND may be floated or connected to either bus depending upon the customer requirements for positive bus or negative bus.

### Interface Connector

The power shelf has an optional DSB, 25-pin, female interface connector on the back. The power system can be monitored and controlled through this interface

### Pin Assignment of the Interface Connector

Pin Number	Signal Name	Description
1	DC Fail_2	DC fail signal of the second power module*.
2	A2	I <sup>2</sup> C address bit 2.
3	A3	I <sup>2</sup> C address bit 3.
4	ON SYNC	Power-on synchronization for multi-shelf operation
5	SDA	I <sup>2</sup> C serial data bus
6	SCL	I <sup>2</sup> C clock
7	NC	No connection
8	On/Off_1 (Optional)	Remote On/Off control for the first power module*.
9	OTP_1	Fan fail or over temp. signal of the first power module*.
10	On/Off_2 (Optional)	Remote On/Off control for the second power module*.
11	Vaux** (Optional)	Provide an auxiliary voltage for customer's system usage.
12	DC Fail_1	DC fail signal of the first power module*.
13	AC Fail_3 (Optional)	AC fail signal of the third power module*.
14	OTP_3	Fan fail or over temp. signal of the third power module*.
15	DC Fail_3	DC fail signal of the third power module*.
16	INT BUS	Intermediate DC bus. It is for shelf internal usage.
17	AC Fail_1 (Optional)	AC fail signal of the first power module*.
18	On/Off_3 (Optional)	Remote On/Off control for the third power module*.
19	SRTN	Signal return and Vaux return.
20	RS-	Remote sense for V-
21	OTP_2	Fan fail or over temp. signal of the second power module*.
22	RS+	Remote sense for V+
23	AC Fail_2 (Optional)	AC fail signal of the second power module*.
24	CS	A single-wire interface for current sharing.
25	V-	V-.

\*Refer to "Mechanical Outline" for the locations of power module 1, 2 and 3.

\*\* Vaux is optional to provide a 10 watts of auxiliary power to external system under request.

## R3000 FRONT END AC-DC POWER SHELF

AC Input: 180V to 264V  
DC Output: 48V to 57V, 3000W

## Product Specification



### Powerstax A1000 series Power Modules

Please see Powerstax data sheets for detail )

The A1000 series power shelf is intended for operation with the Powerstax R3000 series power modules. These modules convert the AC input power to a regulated, low-noise DC bus voltage. Modules are available with up to 1000W.

ORing diode is used at the output of each module to prevent the module from bringing down the bus voltage either during hot insertion or as the result of a module fault. The connectors between the power module and shelf are selected to prevent from blind mating and support hot insertion and removal. Active current sharing between paralleled modules and shelves distribute the load evenly between multiple power units.

### Fault & Status Reporting

The A1000 series power modules provide a number of status report and remote control features. Those signals are aggregated on the host interface on the back of the shelf. Please refer to the module's data sheet for detailed definition of each signal. Host interface is optional for the shelf.

### Fault Management

The modules are fully protected from damaging either the load or themselves under single fault or abnormal operating conditions.

Fault or Abnormal Condition	Response
AC Input Surges and Transients	The robust design of these units provides superior immunity to AC line transients and surges.
Loss of AC Input Power	The module will continue operation without interruption or assertion of the POWER FAIL WARNING signal within 1/2 cycle of outages of main power. Typical holdup time is 20ms.
Output Overvoltage	Under any single fault condition, the output voltage will not exceed 64V.
Internal Overheating	The module is fully protected against damage from excessive heat. The unit will automatically recover once it has cooled down.
Output Overload	When output current exceeds maximum limit, the module goes into a constant power mode and output voltage falls. The unit will run in hiccup mode when the output voltage is below 39V ( $\pm 2V$ ).

### Visual Indicators

Each power module (A1000) has two LEDs to provide visual status information. Please see the following table for these indicators.

Name	Colour Illumination	Meaning
<b>LED 1</b> AC OK	Green	Input voltage OK
<b>LED 2</b> Output OK or Output fail	Green Amber	The unit is powered up and operating normally or The unit has detected an internal fault or overload condition.

### EMI Performance

The shelf will meet CISPR Class B, conducted emissions – EN55022 stand-alone.



**Mechanical Outline**

Dimensions are in millimetres ( inches ).

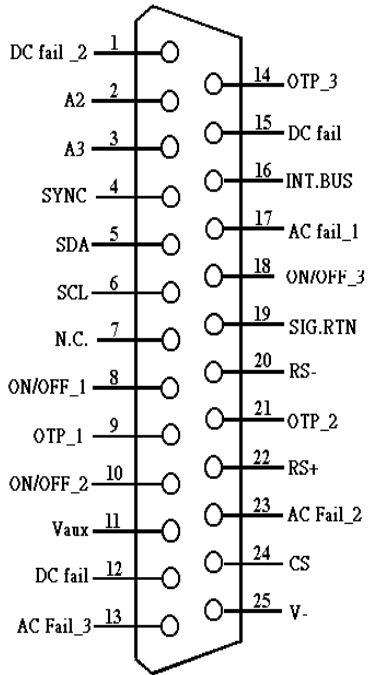
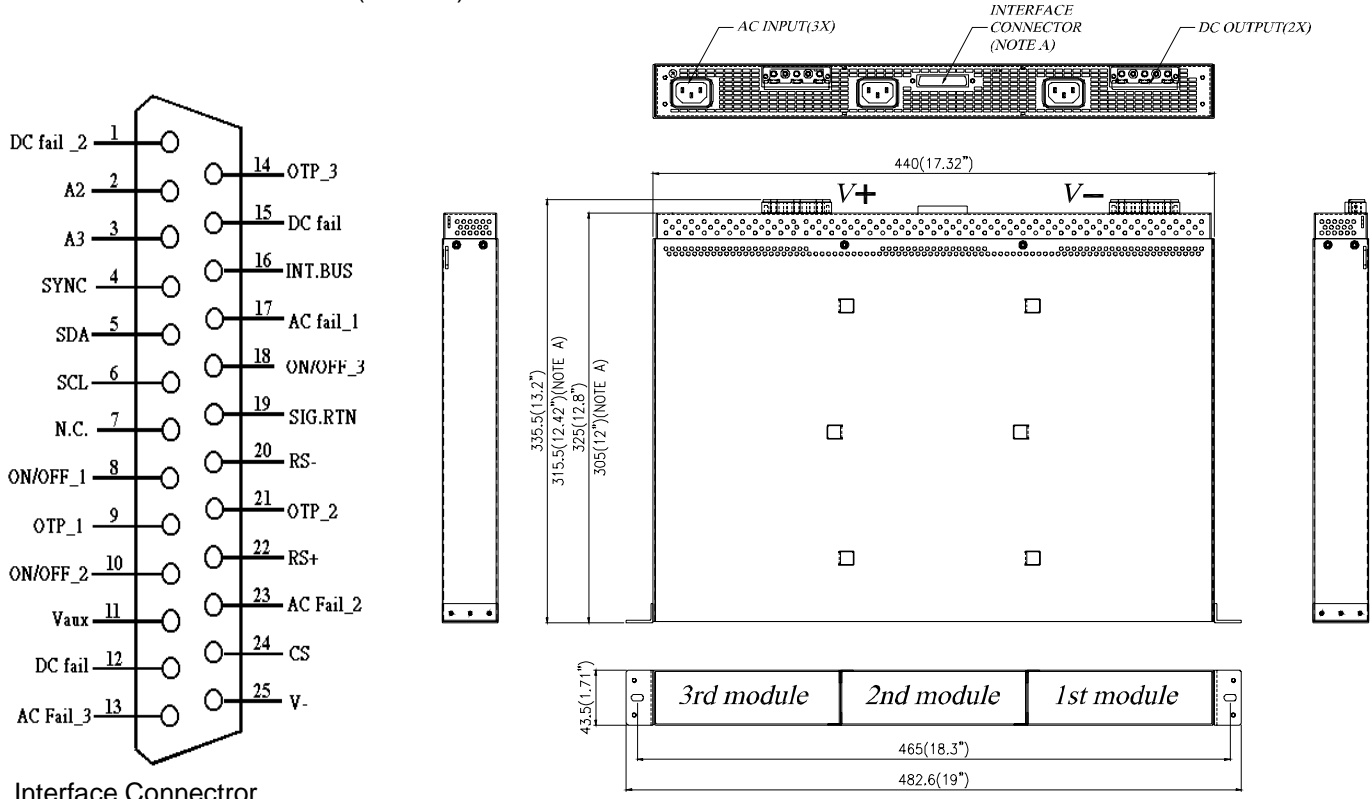

Interface Connector

NOTE A : Entry level, short version, without interface connector

Fig 1. R3000 series Power Shelf

**Selection Guide**

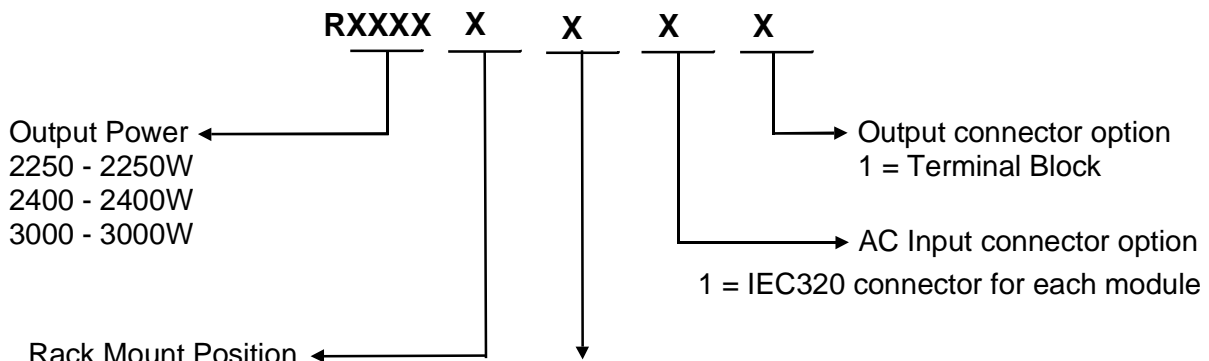

Rack Mount Position

A - Flush (standard)  
B - 127mm back from front panel

Interface connector	On/off 1,2,3	AC fail 1,2,3	Vaux
0	No connector		
1	On ( default )	N.C.	N.C.

# R3000 FRONT END AC-DC POWER SHELF

AC Input: 180V to 264V  
DC Output: 48V to 57V, 3000W

## Product Specification



### Stacked Assembly

Please consult Powerstax to stack up power shelves.

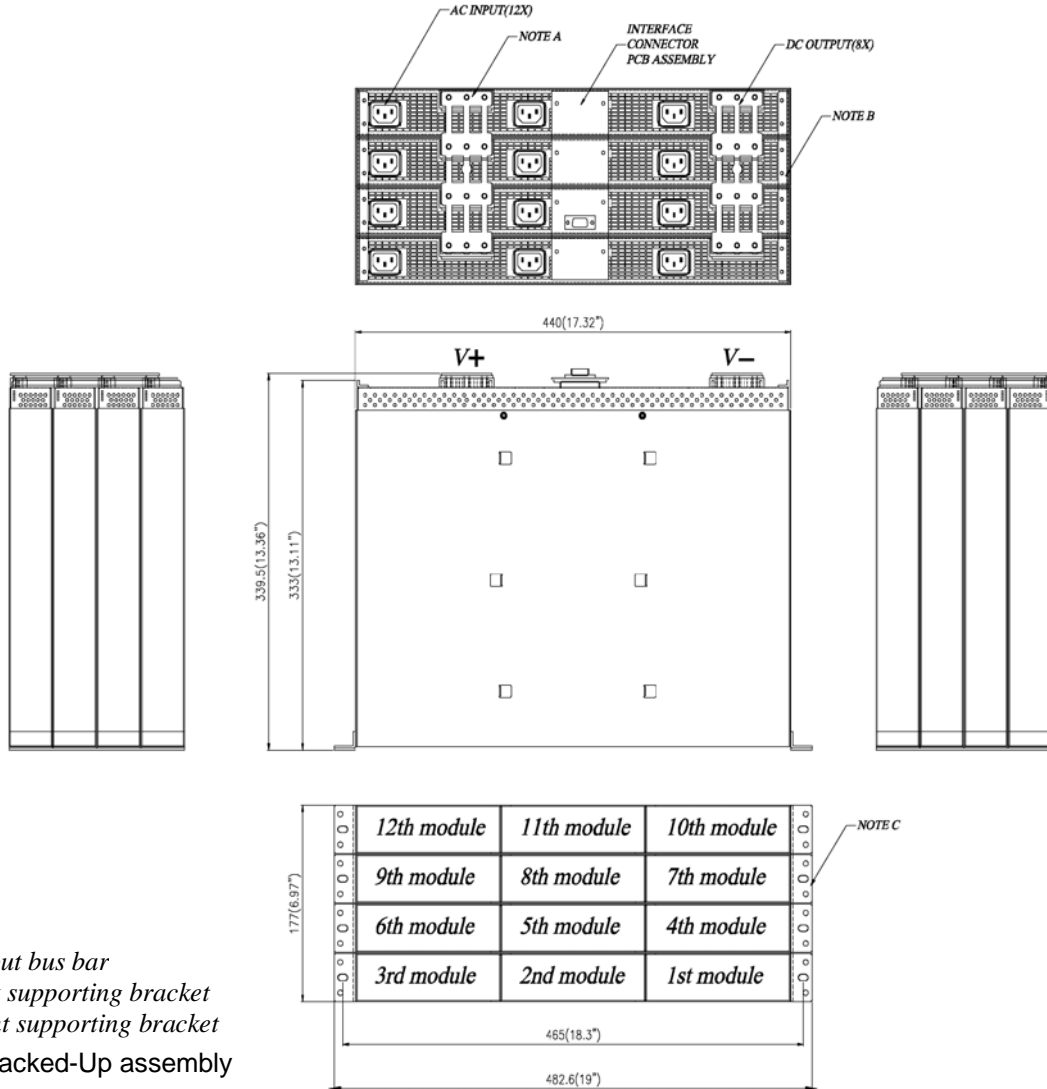

Note A: Output bus bar  
Note B: Back supporting bracket  
Note C: Front supporting bracket

Fig 3. 4U Stacked-Up assembly

### Accessory

Product Name  
Dummy Front Panel for R3000 Power Shelf  
Part Ref: ZBLP-001

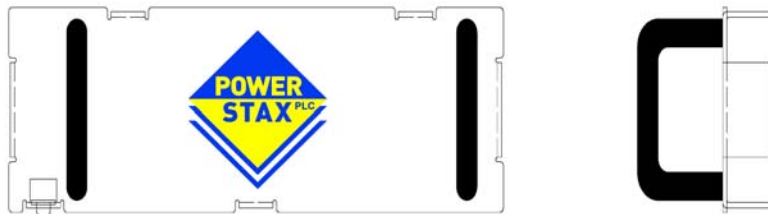

Fig 2. Dummy Front Panel for Powerstax R3000 series Power Shelf

Information & specifications contained in this data sheet are believed to be correct at the time of publication. However, Powerstax accept no responsibility for consequences arising from printing errors or inaccuracies. Specifications are subject to change without notice

