

Input Ranges :

10-75 VDC

Output Output:

Single Output

1.2V - 7.5V

Bipolar Output

±12V, ±15V

Dual Output

+5.0V/+3.3V,

Triple Output

3.3V/12V/12V

5.0V/12v/12V

Output Power:

75 to 200 W

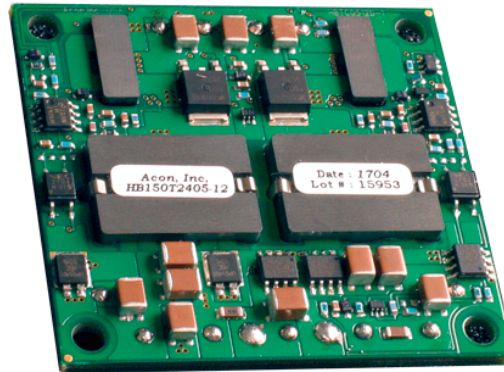

HB series is a family of high power density, high efficiency, and high reliability DC-DC Converters. It provides up to 200W output in a 2.28” x 2.40” footprint.

FEATURES

General:

- Small footprint : 2.28” x 2.40”
- High output power : to 200 watts
- Wide input range : 10-75Vdc
- Open frame or Encapsulated
- Integral PCB transformer
- High conversion efficiency to 92%
- Line & load regulation to ±0.1%
- Fixed operating frequency

Protection:

- Output over-voltage protection
- Output over-load protection
- Hiccup mode short circuit protection
- Over-temperature protection
- Input under-voltage lock-out

Control:

- Enable (On/Off) Control
- Output Voltage Trim

Isolation:

- Isolation Voltage > 1500V

APPLICATIONS

- Distributed Power Systems
- Workstations
- Computer Equipment
- Communications Equipment

Integral PCB transformer / inductor is used for all models in this series. This new design technique has greatly improved the magnetic coupling, reduced switching spike and provided performance consistency. It also streamlines the production process by completely eliminating the hand-wind magnetic assembly process from production lines.

HB series provides the most extensive protection to safeguard both the power converter and the load. It includes output over-voltage protection, over-current protection, hiccup mode indefinite short circuit protection, under-voltage lockout and over-temperature protection. Over-current inception point is set at about 115% of rated load. Hiccup mode cycles at 28mSec period with 3mSec on and 25mSec off. Over-temperature shutdown activated at +115°C board temperature will recover when the temperature falls below +95°C.

HB series features low output noise, very tight line and load regulation, and high efficiency. No external capacitor requirement for normal operation.

TABLE OF CONTENTS :

General Specifications	2
Single Output	4
Bipolar Output	6
Dual Output.....	8
Triple Output.....	10

1. Absolute Maximum Ratings

Stresses in excess of the absolute maximum ratings can cause performance degradation, adversely effect longterm reliability, and cause permanent damage to the device.

Parameter	Conditions / Description	Min	Max	Units
Input Voltage				
Continuous	12	-0.3	22	Vdc
	24	-0.3	38	Vdc
	48	-0.3	78	Vdc
	30	-0.3	32	Vdc
	60	-0.3	62	Vdc
Transient (100mSec.)	12	-0.3	24	Vdc
	24	-0.3	40	Vdc
	48	-0.3	80	Vdc
	30	-0.3	34	Vdc
	60	-0.3	64	Vdc
Operating Temperature	All models, base plate temperature	-55	+105	°C
Storage Temperature	Ambient	-55	+125	°C
Isolation Voltage	Input to Output		+2000	Vdc

2. Input Specifications

Parameter	Conditions / Description	Min	Nom	Max	Units
Input Voltage					
Voltage Range (Continuous)	12	10	12	20	Vdc
	24	18	24	36	Vdc
	48	36	48	75	Vdc
	30	10	24	30	Vdc
	60	20	48	60	Vdc
Under-Voltage Lockout (UVLO)					
Turn-On Threshold (Ramping Up)	12		9.7		Vdc
	24		17		Vdc
	48		35		Vdc
	30		9.7		Vdc
	60		17		Vdc
Turn-Off Threshold (Ramping Down)	12		9.7		Vdc
	24		16		Vdc
	48		33		Vdc
	30		9.2		Vdc
	60		16		Vdc

3. Enable (On-Off Control)

Parameter	Conditions / Description	Min	Nom	Max	Units
Negative Logic					
On-Control	Standard				
Off-Control	(or Floating Enable Pin)	-0.5		1.8	Vdc
		2.5		10	Vdc
Positive Logic					
	Optional (Please add Suffix P)				
On-Control	(or Floating Enable Pin)	2.5		10	Vdc
Off-Control		-0.5		1.8	Vdc
Open Circuit Voltage	Enable pin is floating		10		Vdc
Source Current	Enable pin is connected to -Vin		0.5	1	mA

4. Output Specifications

Parameter	Conditions / Description	Min	Nom	Max	Units
Voltage Accuracy	Please see table				%
Output Current	Please see table				A _{dc}
Output Trim	Available for single output only			±10	%V _{out}
Over Voltage Protection	Not available				V _{dc}
Line Regulation	Please see table				%V _{out}
Load Regulation	Please see table				%V _{out}
Transient Response	50% ± 25% step load change		400		µSec.
Ripple & Noise	Please see table				mVp-p
Switching Frequency			300		KHz

5. Output Trim

Parameter	Conditions / Description	Min	Nom	Max	Units
Negative Trim	Optional - Add Suffix N)				
Trim Up	Trim Pin to (-)Sense			10	%V _{dc}
Trim Down	Trim Pin to (+)sense	10			%V _{dc}
Positive Trim	Standard				
Trim Up	Trim Pin to (+)Sense			10	V _{dc}
Trim Down	Trim Pin to (-)Sense	10			V _{dc}

5. Environmental and Mechanical Specifications

Parameter	Conditions / Description	Min	Nom	Max	Units
Operating Temperature	PCB Temperature				
Standard		-25		+105	°C
Extended		-55		+105	
Storage Temperature		-55		+125	°C
Temperature Coefficient				±0.02	%/°C
Shock	Halfsine wave, 3 axes	50			g
Sinusoidal Vibration	GR-63-CORE, Section 5.4.2	1			g
Humidity	Relative Humidity, Non-Condensing			95	%R.H.
Weight					
Open Frame			2.8(80)		Oz(g)
Encapsulated			4.0(114)		Oz(g)
MTBF (calculated)	Bellcore TR-NWT-000332 method 1 - parts count	1			MHrs

6. Isolation Specifications

Parameter	Conditions / Description	Min	Nom	Max	Units
Insulation Safety Rating	Basic				
Isolation Voltage	Input to Output	1500			V _{dc}
Isolation Resistance	Input to Output	10			MΩ
Isolation Capacitance	Input to Output		3		nF

7. Protections

Parameter	Conditions / Description	Min	Nom	Max	Units
Overcurrent Protection					
Type	Hiccup Mode, Non-Latching, Auto-Recovery				
Threshold	% Rated Load		120		%
Short Circuit			115		A _{RM} S
Overtemperature Protection					
Type	Non-Latching, Auto-Recovery				
Threshold	PCB Temperature		115		°C
Hysteresis			15		°C

BLOCK DIAGRAM

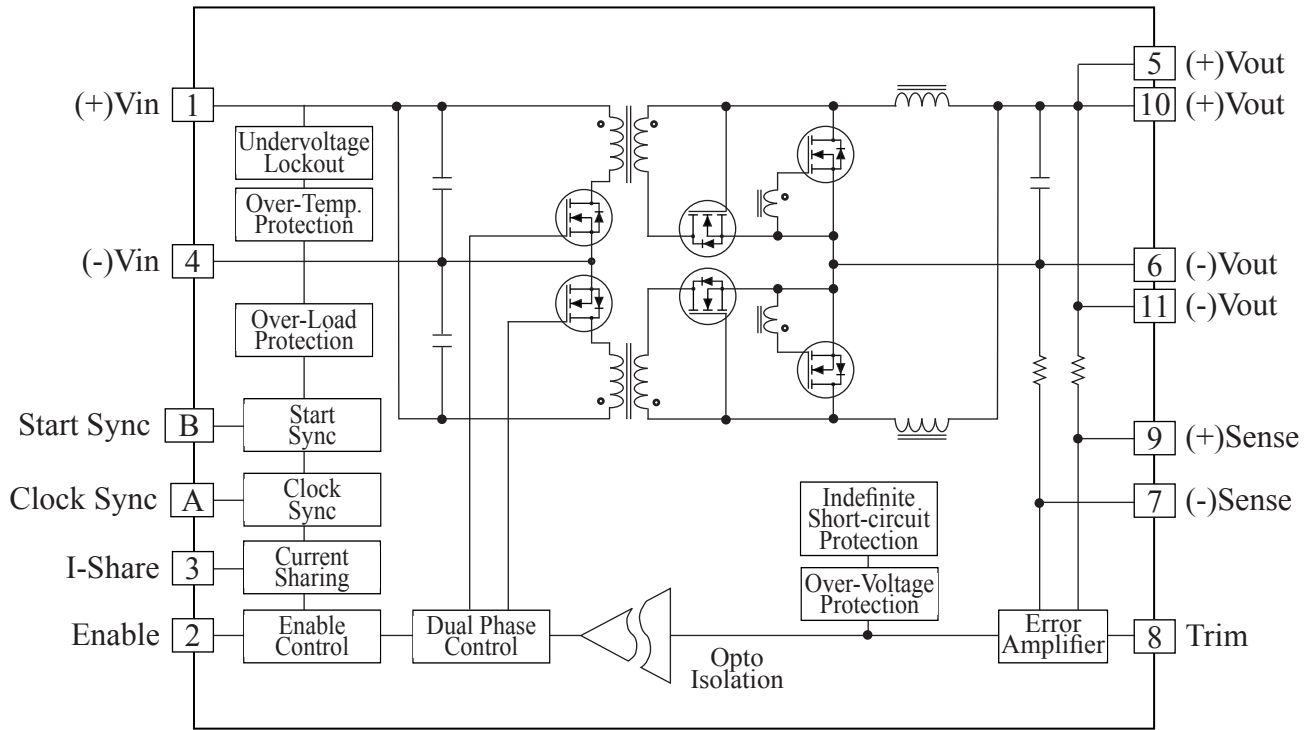

Current Sharing Connections

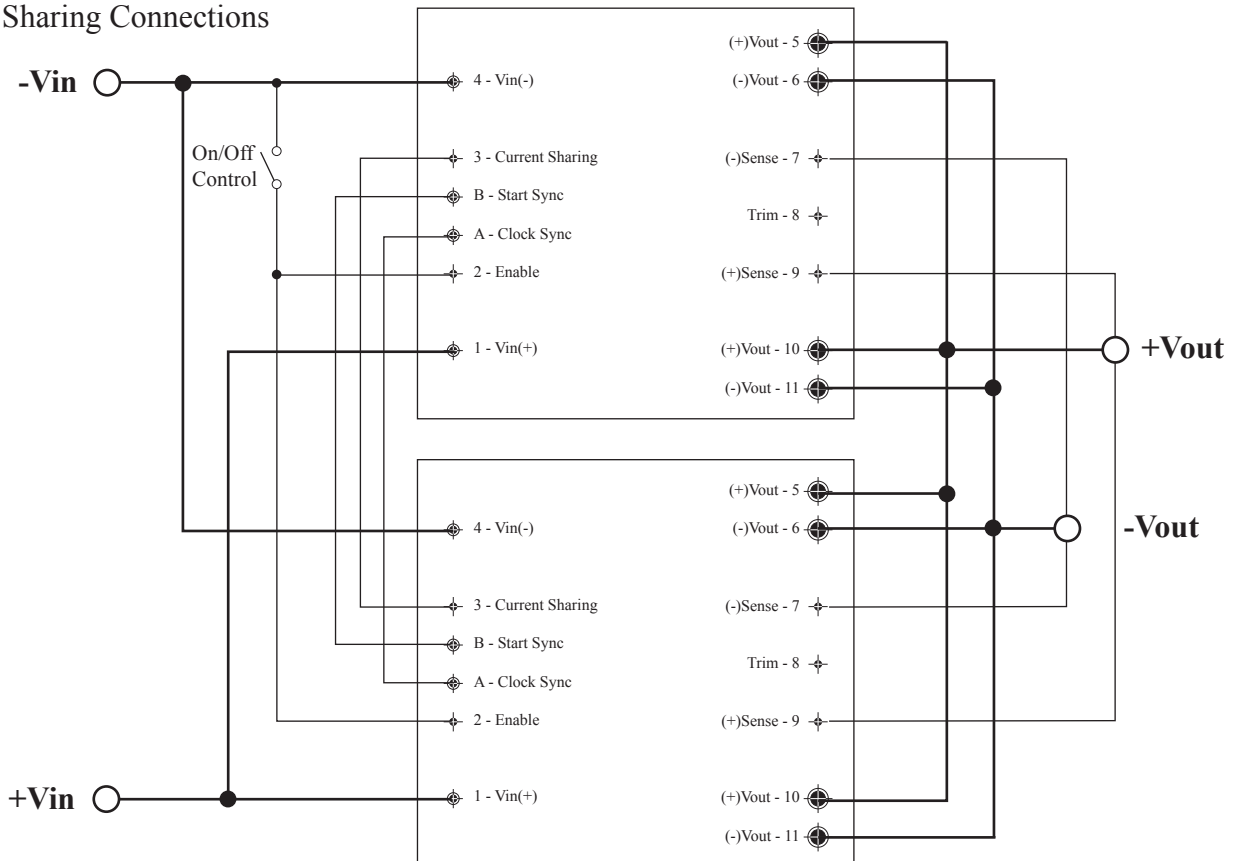

INPUT			OUTPUT							Over Temp. Shutdown /Recover	EFF. (typ.) ³	MODEL NO. ⁴		
Nominal Voltage (Range)	Under Voltage Lockout (typ.)		Voltage (V)	Current (Amp.)	Power (Watt)	Regulation (max.)		Ripple & Noise (typ.)					OVP (max.)	Short Circuit Protection
	On	Off				Line	Load ¹⁾	Peak-Peak	RMS					
48 (36-75)	34	33	1.5V	0 - 80A	120W	±0.1%	±0.1%	50mV	12mV	1.8V	Hiccup Mode Indefinite	+105°C/ +95°C	86%	HB80S48015
			1.8V	0 - 80A	144W	±0.1%	±0.1%	50mV	12mV	2.2V			87%	HB80S48018
			2.5V	0 - 70A	175W	±0.1%	±0.1%	50mV	12mV	3.0V			89%	HB70S48025
			3.3V	0 - 60A	200W	±0.1%	±0.1%	75mV	15mV	4.0V			90%	HB60S48033
			5.0V	0 - 40A	200W	±0.1%	±0.1%	75mV	15mV	5.9V			91%	HB40S4805
			7.5V	3.0 - 30A	200W	±0.1%	±0.1%	100mV	20mV	12V			92%	HB30S48075

¹⁾ 10% min. load required for Vout > 5 V

²⁾ Ripple noise measured with X1 probe tip & ground ring.

Standard Pin-Out

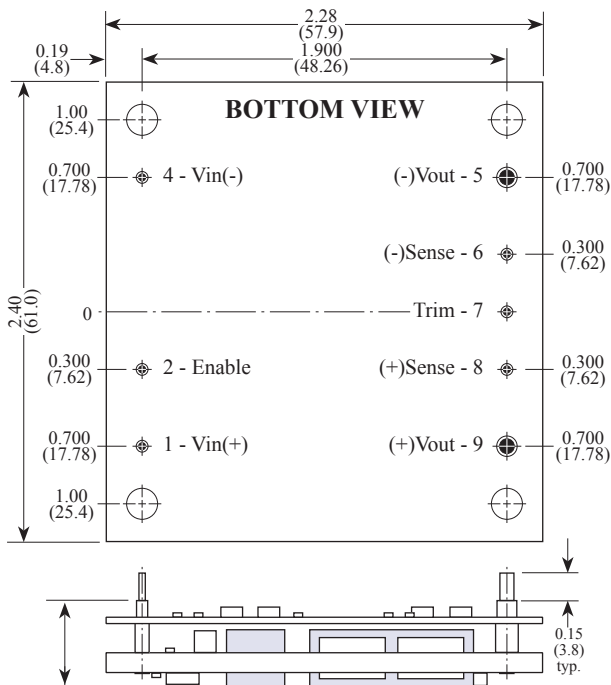

- Pins 5, 9 are 0.080" (2.03mm) dia. with 0.11" (2.79mm) dia. standoff shoulders.
- All other pins are 0.040" (1.02mm) dia. with 0.065" (1.65mm) dia. standoff shoulders.
- Tolerances: x.xx in. ±0.01 in. (0.25 mm)
x.xxx in. ±0.005 in. (0.13 mm)

A Pin-Out (Optional, A Suffix)

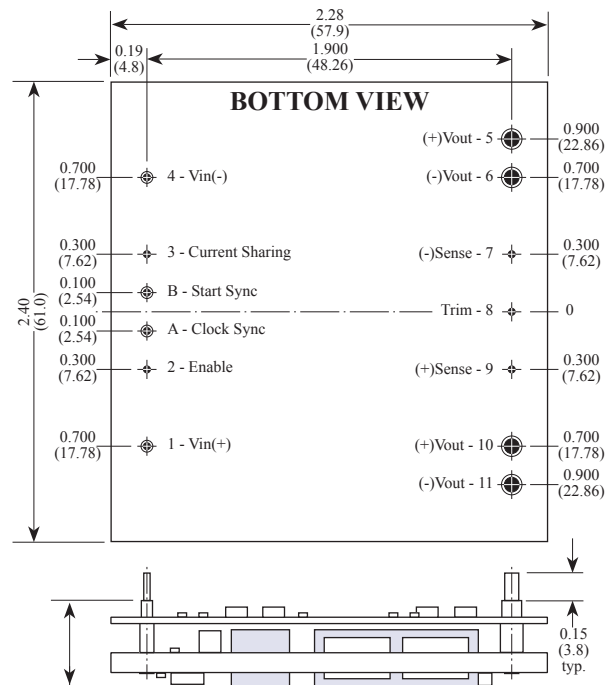

- Pins 1, 4, A, B are 0.040" (1.02mm) dia. with 0.065" (1.65mm) dia. standoff shoulders.
- Pins 5, 6, 10, 11 are 0.080" (2.03mm) dia. with 0.11" (2.79mm) dia. standoff shoulders.
- All other pins are 0.040" (1.02mm) dia.
- All pins are Brass with Tin/Lead plating over Nickel.
- Tolerances: x.xx in. ±0.01 in. (0.25 mm)
x.xxx in. ±0.005 in. (0.13 mm)

Product Numbering System & Selection Guide

HB	30	S	48	015	MC
Series No.	Output Current	No Output	Input Voltage Range	Output Voltage	Options
HB	30 : 30A 40 : 40A 60 : 60A 80 : 80A	S : Single	48 : 36-75V	015 : 1.5V 018 : 1.8V 025 : 2.5V 033 : 3.3V 05 : 5.0V 075 : 7.5V	A : A Pin-Out C : Extended Temp. MC : Metal Case N : Negative Trim P : Positive Enable

DUAL OUTPUT BLOCK DIAGRAM

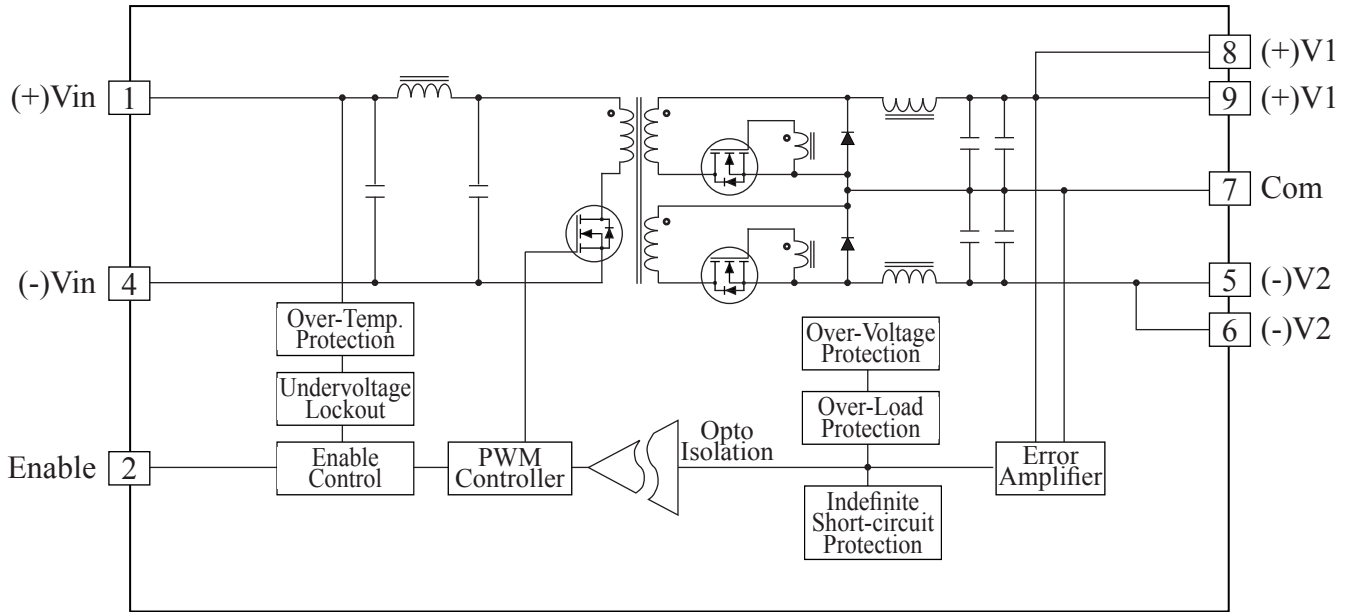

Open Frame (Standard)

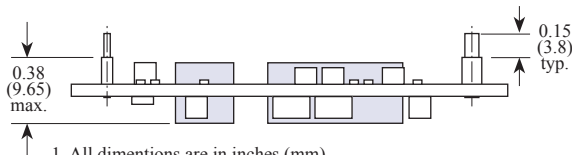
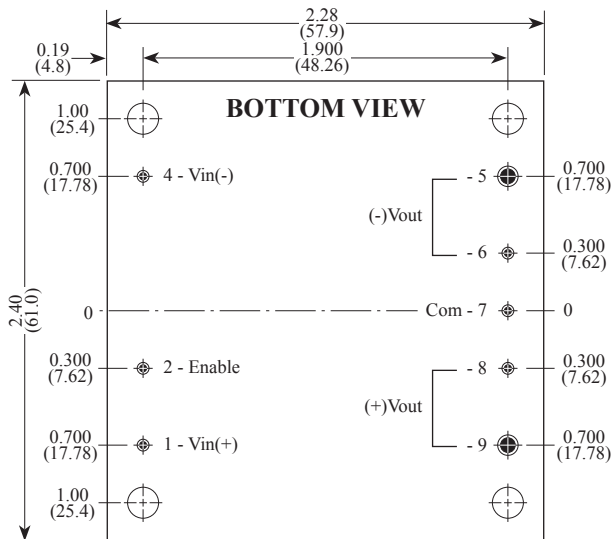

1. All dimensions are in inches (mm)
2. Pins 5, 6, 8, 9 are 0.080" (2.03mm) dia. with 0.11" (2.79mm) dia. standoff shoulders.
3. All other pins are 0.040" (1.02mm) dia. with 0.065" (1.65mm) dia. standoff shoulders.
4. All pins are Brass with Tin/Lead plating over Nickel.
5. Tolerances: x.xx in. \pm 0.01 in. (0.25 mm)
x.xxx in. \pm 0.005 in. (0.13 mm)

Metal Case (Optional, MC Suffix)

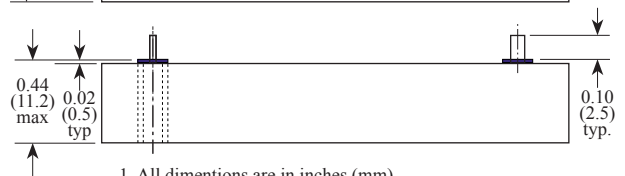
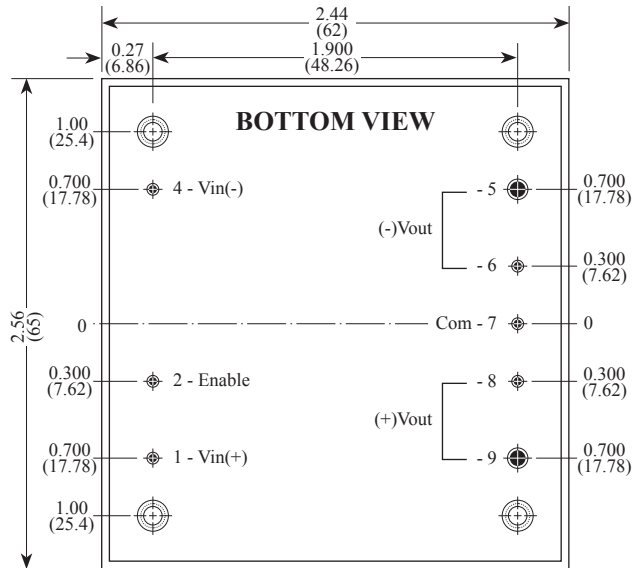

1. All dimensions are in inches (mm)
2. Pins 5, 9 are 0.080" (2.03mm) dia.
3. All other pins are 0.040" (1.02mm) dia.
4. All pins are Brass with Tin/Lead plating over Nickel.
5. Tolerances: x.xx in. \pm 0.01 in. (0.25 mm)
x.xxx in. \pm 0.005 in. (0.13 mm)

INPUT			OUTPUT										Short Circuit Protection	Over Temp. Shutdown /Recover	EFF. (typ.)	MODEL NO.
Nominal (Range)	Under Voltage Lockout (typ.)		Power (Watt)	Voltage				Current (A)			Ripple & Noise*					
	On	Off		#	Set Point	Min.	Max.	#	Min.	Max.	Peak-Peak	R.M.S.				
12 (10-20)	9.7	9.2	100W	+V1	+12.00	+11.88	+12.12	+I1	+0.1	+4.0	50mV	12mV	Hiccup Mode Indefinite	+105°C /+95°C	88%	HB4D1212
				-V2	-12.00	-11.70	-12.20	-I2	-0.1	-4.0	60mV	18mV			88%	HB3D1215
			100W	+V1	+15.00	+14.85	+15.15	I1	+0.1	+3.4	80mV	20mV			88%	HB6D1212
				-V2	-15.00	-14.60	-15.30	I2	-0.1	+3.4	100mV	25mV			88%	HB5D1215
			150W	+V1	+12.00	+11.88	+12.12	+I1	+0.1	+6.0	50mV	12mV			89%	HB4D2412
				-V2	-12.00	-11.70	-12.20	-I2	-0.1	-6.0	60mV	18mV			89%	HB3D2415
24 (18-36)	17	16	100W	+V1	+15.00	+14.85	+15.15	I1	+0.1	+3.4	80mV	20mV			89%	HB6D2412
				-V2	-15.00	-14.60	-15.30	I2	-0.1	+3.4	100mV	25mV			89%	HB5D2415
			150W	+V1	+12.00	+11.88	+12.12	+I1	+0.1	+6.0	50mV	12mV			89%	HB4D4812
				-V2	-12.00	-11.70	-12.20	-I2	-0.1	-6.0	60mV	18mV			89%	HB3D4815
			150W	+V1	+15.00	+14.85	+15.15	I1	+0.1	+5.0	80mV	20mV			89%	HB4D3012
				-V2	-15.00	-14.60	-15.30	I2	-0.1	+5.0	100mV	25mV			88%	HB3D1215
48 (36-75)	34	32	100W	+V1	+12.00	+11.88	+12.12	+I1	+0.1	+4.0	50mV	12mV			89%	HB4D6012
				-V2	-12.00	-11.70	-12.20	-I2	-0.1	-4.0	60mV	18mV			89%	HB3D6015
			100W	+V1	+15.00	+14.85	+15.15	I1	+0.1	+3.4	80mV	20mV				
				-V2	-15.00	-14.60	-15.30	I2	-0.1	+3.4	100mV	25mV				
			150W	+V1	+12.00	+11.88	+12.12	+I1	+0.1	+6.0	50mV	12mV				
				-V2	-12.00	-11.70	-12.20	-I2	-0.1	-6.0	60mV	18mV				
12, 24 (10-30)	17	16	100W	+V1	+15.00	+14.85	+15.15	I1	+0.1	+3.4	80mV	20mV				
				-V2	-15.00	-14.60	-15.30	I2	-0.1	+3.4	100mV	25mV				
			100W	+V1	+12.00	+11.88	+12.12	+I1	+0.1	+4.0	50mV	12mV				
				-V2	-12.00	-11.70	-12.20	-I2	-0.1	-4.0	60mV	18mV				
			100W	+V1	+15.00	+14.85	+15.15	I1	+0.1	+3.4	80mV	20mV				
				-V2	-15.00	-14.60	-15.30	I2	-0.1	+3.4	100mV	25mV				
24, 48 (20-60)	34	32	100W	+V1	+12.00	+11.88	+12.12	+I1	+0.1	+4.0	50mV	12mV				
				-V2	-12.00	-11.70	-12.20	-I2	-0.1	-4.0	60mV	18mV				
			100W	+V1	+15.00	+14.85	+15.15	I1	+0.1	+3.4	80mV	20mV				
				-V2	-15.00	-14.60	-15.30	I2	-0.1	+3.4	100mV	25mV				
			100W	+V1	+12.00	+11.88	+12.12	+I1	+0.1	+6.0	50mV	12mV				
				-V2	-12.00	-11.70	-12.20	-I2	-0.1	-6.0	60mV	18mV				

* Combined Line & Load Regulation (Low Line to High Line & Min. Load to Full Load)

Product Numbering System & Selection Guide

HB	3	D	24	12	MC
Series No.	Output Current	No Output	Input Voltage	Output Voltage	Options
HB	3 : ±3.4A	D : Dual	12 : 10-20V	12 : ±12V	C : Extended Temp.
	4 : ±4.2A		24 : 18-36V	15 : ±15V	MC : Metal Case
	5 : ±5.0A		48 : 36-75V		
	6 : ±6.3A		30 : 10-32V		
			60 : 18-60V		

DUAL OUTPUT BLOCK DIAGRAM

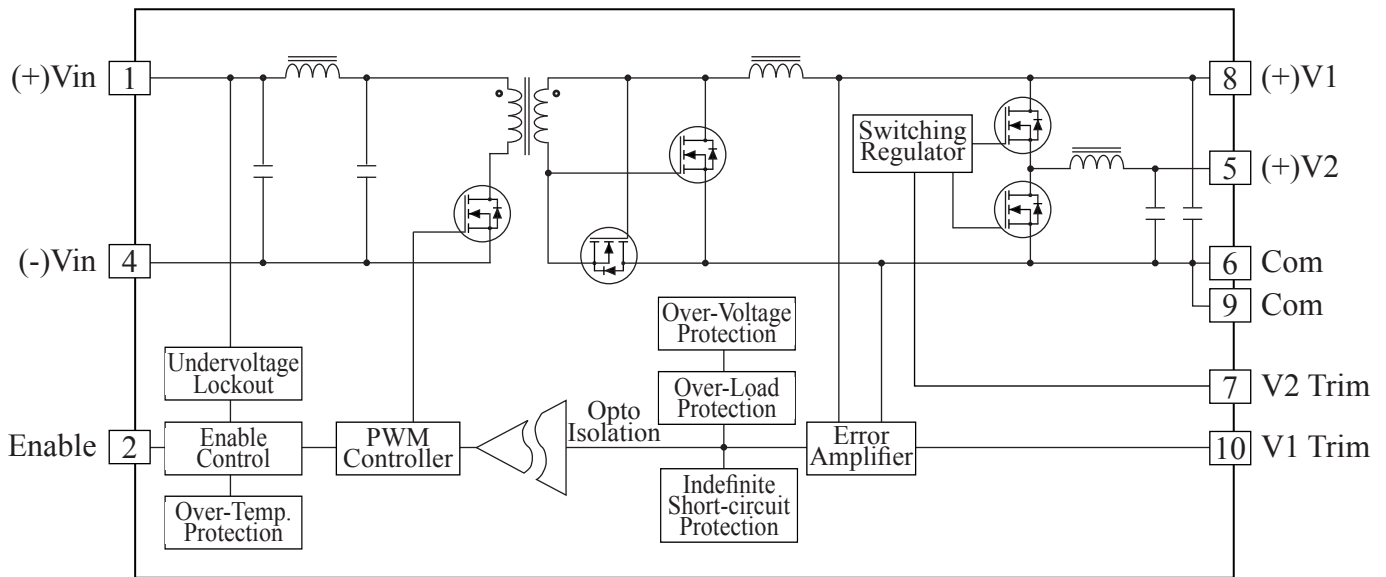

Open Frame (Standard)

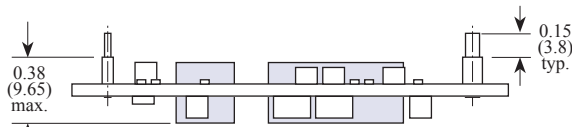
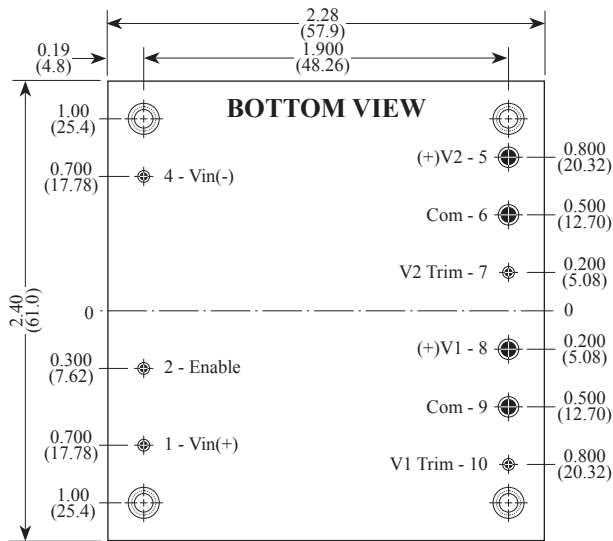

1. All dimensions are in inches (mm)
2. Pins 5, 6, 8, 9 are 0.080" (2.03mm) dia. with 0.11" (2.79mm) dia. standoff shoulders.
3. All other pins are 0.040" (1.02mm) dia. with 0.065" (1.65mm) dia. standoff shoulders.
4. All pins are Brass with Tin/Lead plating over Nickel.
5. Tolerances: x.xx in. ±0.01 in. (0.25 mm)
x.xxx in. ±0.005 in. (0.13 mm)

Metal Case (Optional, MC Suffix)

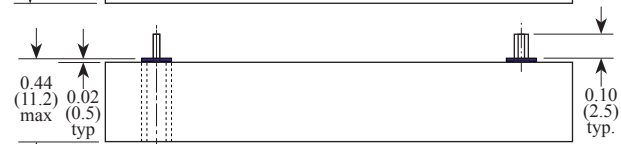
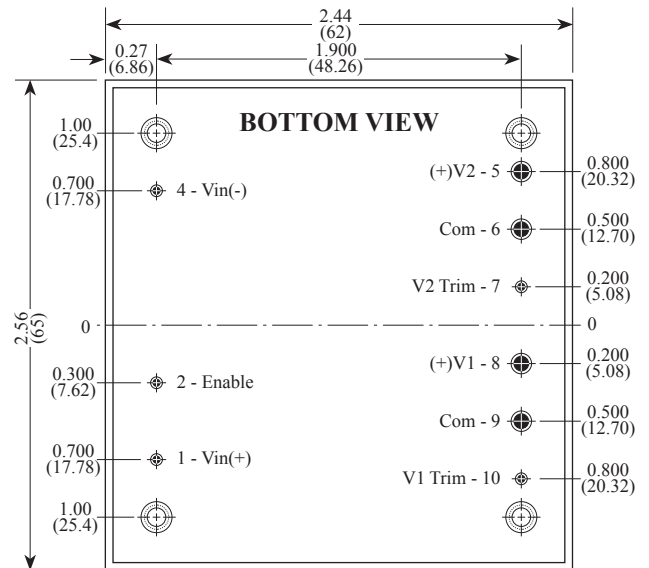

1. All dimensions are in inches (mm)
2. Pins 5, 6, 8, 9 are 0.080" (2.03mm) dia.
3. All other pins are 0.040" (1.02mm) dia.
4. All pins are Brass with Tin/Lead plating over Nickel.
5. Tolerances: x.xx in. ±0.01 in. (0.25 mm)
x.xxx in. ±0.005 in. (0.13 mm)

INPUT			OUTPUT										Over Temp. Shutdown /Recover	EFF. (typ.)	MODEL NO.							
Nominal (Range)	Under Voltage Lockout (typ.)		Power (Watt)	Voltage				Current (A)			Ripple & Noise*					Short Circuit Protection						
	On	Off		#	Set Point	Min.*	Max.*	#	Min.	Max.	Peak-Peak	R.M.S.										
12 (10 - 20)	9.7	9.2	60W	+V1	+5.00	+4.95	+5.10	+I1	+0	+12	75mV	12mV	Hiccup Mode Indefinite	+105°C /+95°C	89%	HB1210D1205-033						
				+V2	+3.30	+3.25	+3.34	-I2	+0	+10	50mV	18mV			88%	HB2018D1205-033						
			100W	+V1	+5.00	+4.95	+5.10	+I1	+0	+20	75mV	12mV			89%	HB1210D2405-033						
				+V2	+3.30	+3.25	+3.34	-I2	+0	+18	50mV	18mV			89%	HB2018D2405-033						
24 (18-36)	17	16	60W	+V1	+5.00	+4.95	+5.10	+I1	+0	+12	75mV	12mV			Hiccup Mode Indefinite	+105°C /+95°C	89%	HB1210D2405-033				
				+V2	+3.30	+3.25	+3.34	-I2	+0	+10	50mV	18mV					89%	HB2018D2405-033				
			100W	+V1	+5.00	+4.95	+5.10	+I1	+0	+20	75mV	12mV					89%	HB1210D2405-033				
				+V2	+3.30	+3.25	+3.34	-I2	+0	+18	50mV	18mV					89%	HB2018D2405-033				
48 (36-75)	34	33	60W	+V1	+5.00	+4.95	+5.10	+I1	+0	+12	75mV	12mV					Hiccup Mode Indefinite	+105°C /+95°C	89%	HB1210D4805-033		
				+V2	+3.30	+3.25	+3.34	-I2	+0	+10	50mV	18mV							89%	HB2018D4805-033		
			100W	+V1	+5.00	+4.95	+5.10	+I1	+0	+20	75mV	12mV							89%	HB1210D4805-033		
				+V2	+3.30	+3.25	+3.34	-I2	+0	+18	50mV	18mV							89%	HB2018D4805-033		
30 (10-30)	17	16	60W	+V1	+5.00	+4.95	+5.10	+I1	+0	+12	75mV	12mV	Hiccup Mode Indefinite	+105°C /+95°C					87%	HB1210D3005-033		
				+V2	+3.30	+3.25	+3.34	-I2	+0	+10	50mV	18mV							87%	HB2018D3005-033		
60 (20-60)	17	16	75W	+V1	+5.00	+4.95	+5.10	+I1	+0	+12	75mV	12mV							Hiccup Mode Indefinite	+105°C /+95°C	87%	HB1210D6005-033
				+V2	+3.30	+3.25	+3.34	-I2	+0	+10	50mV	18mV									87%	HB2018D6005-033

* Combined Line & Load Regulation (Low Line to High Line & Min. Load to Full Load)

Product Numbering System & Selection Guide

Series No.	Max. Output Current	No Output	Input Voltage	+V1 Output	+V2 Output	Options
HB	1210 : +5V@12A, +3.3V@10A 2018 : +5V@20A, +3.3V@18A	D : Dual	12 : 10-20V 24 : 18-36V 48 : 36-75V 30 : 10-30V 60 : 20-60V	05 : +5.0V	033 : +3.3V	C : -55°C Operation MC : Metal Case

BLOCK DIAGRAM

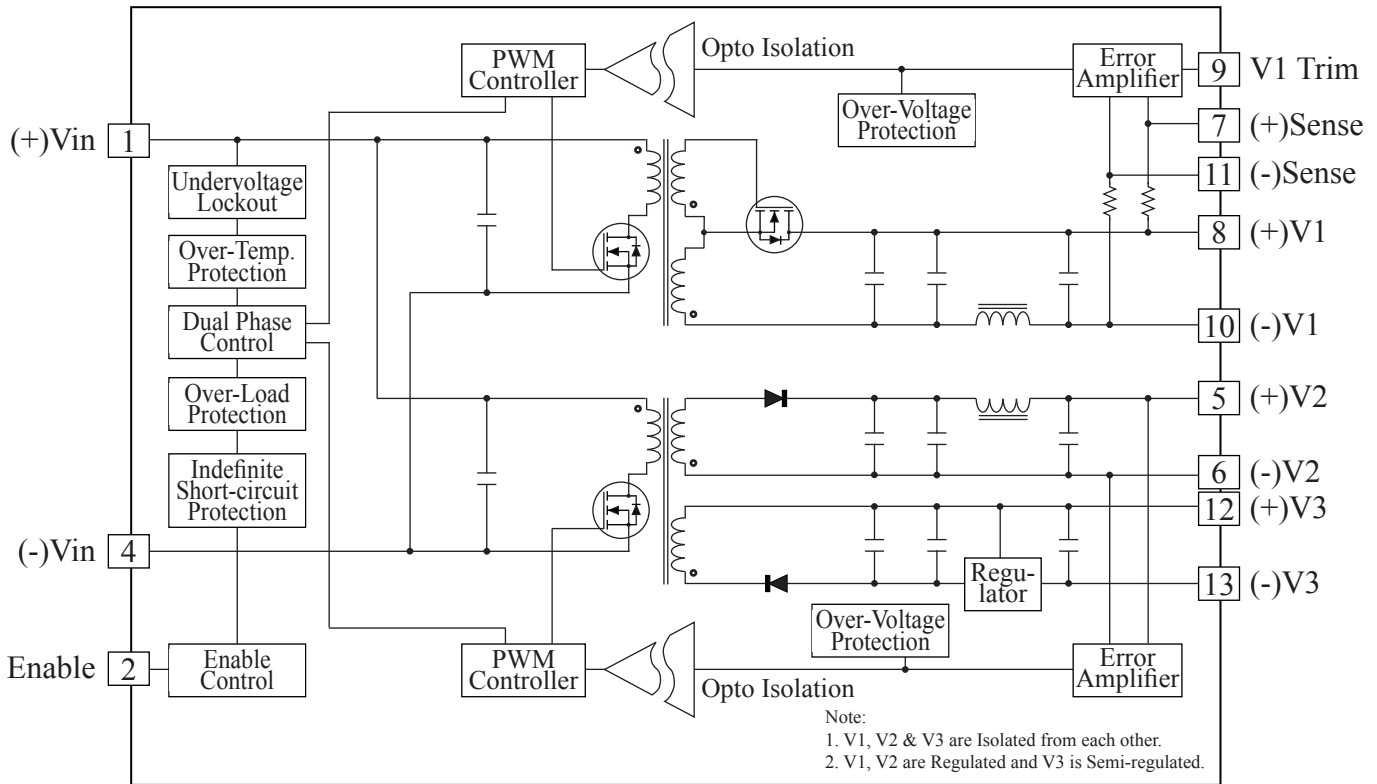

CONNECTION DIAGRAMS

3.3V (or 5V) & ±12V

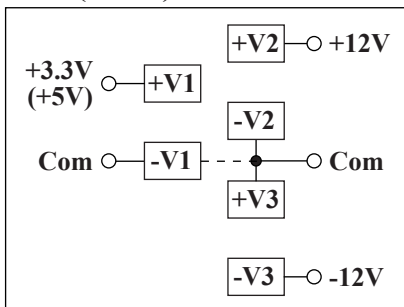

3.3V (or 5V) & 12V

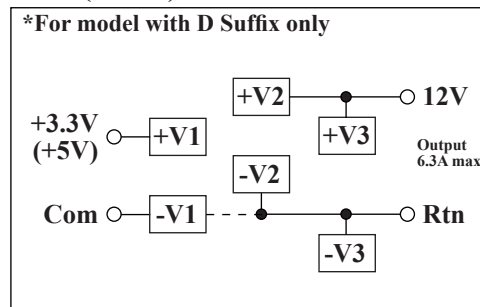

3.3V (or 5V) & 24V

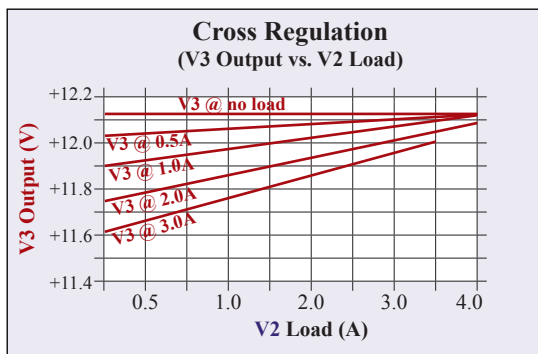
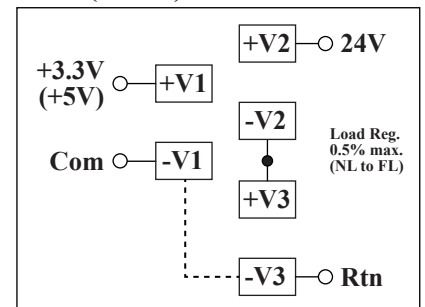

OPEN FRAME (Standard)

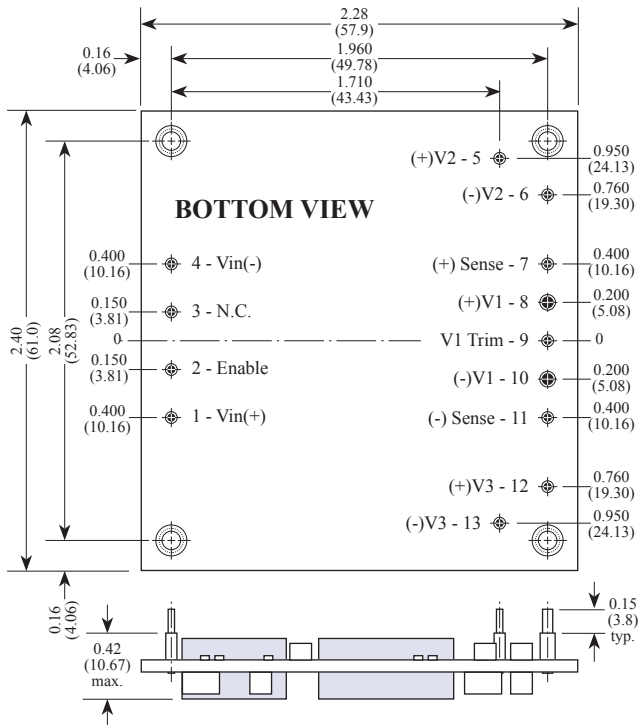

1. All dimensions are in inches (mm)
2. Pins 8, 10 are 0.060" (1.5mm) dia. with 0.11" (2.16mm) dia. standoff shoulders.
3. All other pins are 0.040" (1.02mm) dia. with 0.065" (1.65mm) dia. standoff shoulders.
4. Tolerances: x.xx in. ±0.01 in. (0.25 mm)
x.xxx in. ±0.005 in. (0.13 mm)

METAL CASE (Optional - MC Suffix)

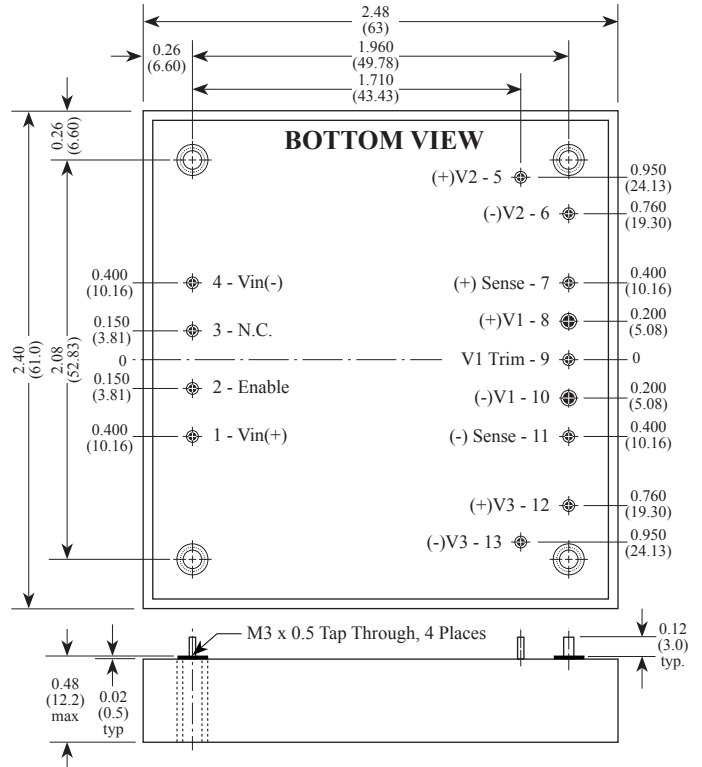

1. All dimensions are in inches (mm)
2. Pins 8, 10 are 0.060" (1.5mm) dia.
3. All other pins are 0.040" (1.02mm) dia.
4. Tolerances: x.xx in. ±0.01 in. (0.25 mm)
x.xxx in. ±0.005 in. (0.13 mm)

Product Numbering System & Selection Guide

HB	100	T	24	05	-12	MC
Series No.	Output Power	No Output	Input Voltage	V1 Output	V2/V3 Output	Options
HB	100 : 100W 150 : 150W	T : Triple	12 : 10-20V 24 : 18-36V 48 : 36-75V 30 : 10-30V 60 : 20-60V	033 : 3.3V 05 : 5.0V	-12 : ±12V	C : Extended Temp. D : V2/V3 Parallel MC : Metal Case

INPUT		Power (Watt)	OUTPUT										Short Circuit Protection	Over Temp. Shutdown /Recover	EFF. (Typ.)	MODEL NO.			
Nominal (Range)	UVLO On/Off		Voltage (V)			Current (A)			Ripple & Noise		OVP (V)								
			#	Set Point	Min.*	Max.*	#	Min.	Max.	Peak-Peak		R.M.S.							
12 (10 - 20)	9.7/ 9.5	100	3.3V	V1	3.30V	3.20V	3.40V	I1	0	15	75mV	15mV	3.9	Hiccup Mode Indefinite	+105°C/ +95°C	88%	HB100T12033-12		
			12V	V2	12.00V	11.88V	12.12V	I2	0.2	2.5	100mV	25mV	14.4						
			12V	V3	12.00V	11.50V	12.50V	I3	0.1	2.0	100mV	25mV							
		140	3.3V	V1	3.30V	3.20V	3.40V	I1	0	20	75mV	15mV	3.9						
		12V	V2	12.00V	11.88V	12.12V	I2	0.4	4.0	100mV	25mV	14.4							
		12V	V3	12.00V	11.50V	12.50V	I3	0.1	3.0	100mV	25mV								
	100	5.0V	V1	5.00V	4.90V	5.10V	I1	0	10	75mV	15mV	5.9							
	12V	V2	12.00V	11.88V	12.12V	I2	0.2	2.5	100mV	25mV	14.4								
	12V	V3	12.00V	11.50V	12.50V	I3	0.1	2.0	100mV	25mV									
	150	5.0V	V1	5.00V	4.90V	5.10V	I1	0	15.0	75mV	15mV	5.9							
	12V	V2	12.00V	11.88V	12.12V	I2	0.4	4.0	100mV	25mV	14.4								
	12V	V3	12.00V	11.50V	12.50V	I3	0.1	3.0	100mV	25mV									
24 (18 - 36)	17/ 16	100	3.3V	V1	3.30V	3.20V	3.40V	I1	0	15	75mV	15mV	3.9			Hiccup Mode Indefinite	+105°C/ +95°C	90%	HB100T24033-12
			12V	V2	12.00V	11.88V	12.12V	I2	0.2	2.5	100mV	25mV	14.4						
			12V	V3	12.00V	11.50V	12.50V	I3	0.1	2.0	100mV	25mV							
		140	3.3V	V1	3.30V	3.20V	3.40V	I1	0	20	75mV	15mV	3.9						
		12V	V2	12.00V	11.88V	12.12V	I2	0.4	4.0	100mV	25mV	14.4							
		12V	V3	12.00V	11.50V	12.50V	I3	0.1	3.0	100mV	25mV								
	100	5.0V	V1	5.00V	4.90V	5.10V	I1	0	10	75mV	15mV	5.9							
	12V	V2	12.00V	11.88V	12.12V	I2	0.2	2.5	100mV	25mV	14.4								
	12V	V3	12.00V	11.50V	12.50V	I3	0.1	2.0	100mV	25mV									
	150	5.0V	V1	5.00V	4.90V	5.10V	I1	0	15.0	75mV	15mV	5.9							
	12V	V2	12.00V	11.88V	12.12V	I2	0.4	4.0	100mV	25mV	14.4								
	12V	V3	12.00V	11.50V	12.50V	I3	0.1	3.0	100mV	25mV									
48 (36 - 75)	34/ 33	100	3.3V	V1	3.30V	3.20V	3.40V	I1	0	15	75mV	15mV	3.9	Hiccup Mode Indefinite	+105°C/ +95°C			90%	HB100T48033-12
			12V	V2	12.00V	11.88V	12.12V	I2	0.2	2.5	100mV	25mV	14.4						
			12V	V3	12.00V	11.50V	12.50V	I3	0.1	2.0	100mV	25mV							
		140	3.3V	V1	3.30V	3.20V	3.40V	I1	0	20	75mV	15mV	3.9						
		12V	V2	12.00V	11.88V	12.12V	I2	0.4	4.0	100mV	25mV	14.4							
		12V	V3	12.00V	11.50V	12.50V	I3	0.1	3.0	100mV	25mV								
	100	5.0V	V1	5.00V	4.90V	5.10V	I1	0	10	75mV	15mV	5.9							
	12V	V2	12.00V	11.88V	12.12V	I2	0.2	2.5	100mV	25mV	14.4								
	12V	V3	12.00V	11.50V	12.50V	I3	0.1	2.0	100mV	25mV									
	150	5.0V	V1	5.00V	4.90V	5.10V	I1	0	15.0	75mV	15mV	5.9							
	12V	V2	12.00V	11.88V	12.12V	I2	0.4	4.0	100mV	25mV	14.4								
	12V	V3	12.00V	11.50V	12.50V	I3	0.1	3.0	100mV	25mV									
30 (10 - 30)	9.7/ 9.5	100	3.3V	V1	3.30V	3.20V	3.40V	I1	0	15	75mV	15mV	3.9			Hiccup Mode Indefinite	+105°C/ +95°C	86%	HB100T30033-12
			12V	V2	12.00V	11.88V	12.12V	I2	0.2	2.5	100mV	25mV	14.4						
			12V	V3	12.00V	11.50V	12.50V	I3	0.1	2.0	100mV	25mV							
		140	3.3V	V1	3.30V	3.20V	3.40V	I1	0	20	75mV	15mV	3.9						
		12V	V2	12.00V	11.88V	12.12V	I2	0.4	4.0	100mV	25mV	14.4							
		12V	V3	12.00V	11.50V	12.50V	I3	0.1	3.0	100mV	25mV								
	100	5.0V	V1	5.00V	4.90V	5.10V	I1	0	10	75mV	15mV	5.9							
	12V	V2	12.00V	11.88V	12.12V	I2	0.2	2.5	100mV	25mV	14.4								
	12V	V3	12.00V	11.50V	12.50V	I3	0.1	2.0	100mV	25mV									
	150	5.0V	V1	5.00V	4.90V	5.10V	I1	0	15.0	75mV	15mV	5.9							
	12V	V2	12.00V	11.88V	12.12V	I2	0.4	4.0	100mV	25mV	14.4								
	12V	V3	12.00V	11.50V	12.50V	I3	0.1	3.0	100mV	25mV									
60 (20 - 75)	17	100	3.3V	V1	3.30V	3.20V	3.40V	I1	0	15	75mV	15mV	3.9	Hiccup Mode Indefinite	+105°C/ +95°C			88%	HB100T60033-12
			12V	V2	12.00V	11.88V	12.12V	I2	0.2	2.5	100mV	25mV	14.4						
			12V	V3	12.00V	11.50V	12.50V	I3	0.1	2.0	100mV	25mV							
		140	3.3V	V1	3.30V	3.20V	3.40V	I1	0	20	75mV	15mV	3.9						
		12V	V2	12.00V	11.88V	12.12V	I2	0.4	4.0	100mV	25mV	14.4							
		12V	V3	12.00V	11.50V	12.50V	I3	0.1	3.0	100mV	25mV								
	100	5.0V	V1	5.00V	4.90V	5.10V	I1	0	10	75mV	15mV	5.9							
	12V	V2	12.00V	11.88V	12.12V	I2	0.2	2.5	100mV	25mV	14.4								
	12V	V3	12.00V	11.50V	12.50V	I3	0.1	2.0	100mV	25mV									
	150	5.0V	V1	5.00V	4.90V	5.10V	I1	0	15.0	75mV	15mV	5.9							
	12V	V2	12.00V	11.88V	12.12V	I2	0.4	4.0	100mV	25mV	14.4								
	12V	V3	12.00V	11.50V	12.50V	I3	0.1	3.0	100mV	25mV									

V1, V2 & V3 are isolated from each other.

* Combined Line & Load Regulation (Low Line to High Line, Min. Load to Full Load). Please see Cross Regulation Curve.